

3 to 4 cell Lithium-ion/Lithium-polymer battery secondary protection protection IC MM3625 Series

Outline

The MM3625 series are secondary protection IC using high voltage CMOS process for overcharge protection of the rechargeable Lithium-ion or Lithium-polymer battery.

The high accuracy overcharge detection of each cell of the rechargeable 3 to 4 cell Lithium-ion or Lithium-polymer battery is possible.

The IC has a regulator and it is possible to stop regulator by detected overdischarge.

The internal circuit of IC is composed by the voltage detector, the reference voltage source, delay time control circuit, the logical circuit, and regulator circuit etc.

Features

(Unless otherwise specified, Topr=+25°C)

(1) Range and accuracy of detection/release voltage

● Overcharge detection voltage	3.6V to 4.5V, 5mV steps	Accuracy±25mV (Topr=0 to +50°C)
● Overcharge release voltage	3.4V to 4.5V, 50mV steps	Accuracy±50mV
● VOU OFF voltage	2.1V to 3.2V, 10mV steps	Accuracy±50mV
● VOUT ON voltage (Note1)	2.3V to 3.4V, 50mV steps	Accuracy±75mV

Note1 : This parameter can set when starting conditions of VOUT are voltage release

(2) Range and accuracy of detection/release delay time (Note2)

● Overcharge detection delay time	1ms to $(1\text{ms} \times 2^{n1}) + (1\text{ms} \times 2^{n2}) + (1\text{ms} \times 2^{n3})$	Accuracy±25%
● Overcharge release delay time	1ms to $(1\text{ms} \times 2^{n1})$	Accuracy±25%
● VOUT OFF delay time	1ms to $(1\text{ms} \times 2^{n1}) + (1\text{ms} \times 2^{n2}) + (1\text{ms} \times 2^{n3})$	Accuracy±25%

Note2 : n1, n2 and n3 can select arbitrary integers between 0 to 17. (However n1≠n2≠n3)

(3) Range and accuracy of regulator output voltage

● VOUT pin output voltage	1.8V to 5.0V, 50mV steps	Accuracy±100mV
---------------------------	--------------------------	----------------

(4) The setting for three cell and for four cell protection can be set with the SEL pin

(5) Regulator output can be control with the EN pin

It does not stop regulator during "H" level is applied to EN pin. When EN pin is "L" level and cell voltage lower than VOUT OFF voltage, it stop regulator

(6) FUSE pin can control with the CTL pin

If "H" level is applied to CTL pin without cell voltage, FUSE pin outputs "H" level.

In case of "L" level is applied to CTL pin, FUSE pin outputs "H" level by overcharge detecton

(7) Low current consumption

● Current consumption1(VDD pin) Vcell=3.5V	Typ. 4.5μA, Max. 6.5μA
● Current consumption1(VDD pin) Vcell=2.5V	Max. 0.1μA (When starting conditions of VOUT are EN pin.) Max. 1.0μA (When starting conditions of VOUT are cell voltage.)

(8) Absolute maximum ratings

●VDD pin	VSS-0.3V to VSS+20V
●Voltage between the input pins of voltage of battery	-0.3V to +10V
●FUSE pin, EN pin, SEL pin,CTL pin supply voltage	VSS-0.3V to VDD+0.3V
●VOUT pin output voltage	VSS-0.3V to VSS+20V
●VOUT pin output current	150μA
●Storage temperature	-55°C to +125°C
●Operating temperature	-55°C to +125°C

(9) Recommended operating conditions

●Operating temperature	-40°C to +85°C
●Supply Voltage	VSS 4.5V to VSS 18.0V
●VOUT pin output current	0 to 100μA

Pin Assignment

Top view PLP-10A	Pin No.	Input / Output	Function	
	1	INPUT	The input terminal of the power supply of IC and the positive voltage of V4 cell.	
	2	INPUT	The input terminal of the positive voltage of V3 cell, and the negative voltage of V4 cell.	
	3	INPUT	The input terminal of the positive voltage of V2 cell, and the negative voltage of V3 cell.	
	4	INPUT	The input terminal of the positive voltage of V1 cell, and the negative voltage of V2 cell.	
	5	INPUT	The input terminal of the negative voltage of V1 cell. The input terminal of the ground of IC.	
	6	INPUT	This terminal is for changing function for 3cell in series or 4cell in series.	
			Input voltage	
			VSS	4Cell in series
			VDD	3Cell in series (Connect V4 and V3 pin)
	7	OUTPUT	Regulator output terminal.	
8	OUTPUT	Charge control output terminal. Output type is CMOS. · Normal mode : Low · Overcharge mode : High		
9	INPUT	Regulator output ON control terminal.		
		Input level		
		High	Regulator output compulsion ON.	
		VSS	Regulator-off detection is possible.	
10	INPUT	FUSE output ON control terminal.		
		Input level		
		VDD	FUSE output High	
		VSS	FUSE output Low	

• Any products mentioned in this catalog are subject to any modification in their appearance and others for improvements without prior notification.
 • The details listed here are not a guarantee of the individual products at the time of ordering. When using the products, you will be asked to check their specifications.

Selection Guide

Product name (MM3625***RRE)	Overcharge detection voltage [V]	Overcharge release voltage [V]	VOUT OFF voltage [V]	VOUT ON voltage [V]	Overcharge detection delay time [sec]	Overcharge output keep time [sec]	Overcharge release delay time [msec]	VOUT OFF delay time [msec]	VOUT pin output voltage [V]	VDD pin Current consumption1 [μA]	VDD pin Current consumption2 [μA]	Overcharger output latch function	Overcharge timer reset delay function	VOUT output starting conditions
	VDET1	VREL1	VDET2	VREL2	tVDET1	tVDET1-2	tVREL1	tVDET2	VOUT	I _{DD1}	I _{DD2}			
A01	4.425		2.750		4.10	90.11		10.0	2.900	6.0	0.1	○		EN pin
A02	4.300		2.500		4.10	90.11		10.0	3.300	6.0	0.1	○		EN pin
B02	4.450	4.250	2.500		4.10		16.0	10.0	3.300	6.0	0.1			EN pin
B03	4.450	4.250	2.750		7.17		16.0	10.0	3.300	6.0	0.1			EN pin
B04	4.500	4.300	2.750		7.17		16.0	10.0	3.300	6.0	0.1			EN pin
Y01(Note4)	4.425		2.750		4.10	90.11		4096.0	2.900	6.0	0.1	○		EN pin
Z01(Note4)	4.425		2.750		4.10	90.11		4096.0	2.900	6.0	0.1	○		EN pin

Note4 : Y01 and Z01 rank do not have a SEL pin. Y01 rank is 3cells protection. Z01 rank is 4cells protection.
 Y01 rank and Z01 rank differ in other rank and operation. Please check by specifications individual for details.

Please inquire to us, if you request a rank other than the above.

• Any products mentioned in this catalog are subject to any modification in their appearance and others for improvements without prior notification.
 • The details listed here are not a guarantee of the individual products at the time of ordering. When using the products, you will be asked to check their specifications.

Application Circuit

· 4 cells protection circuit

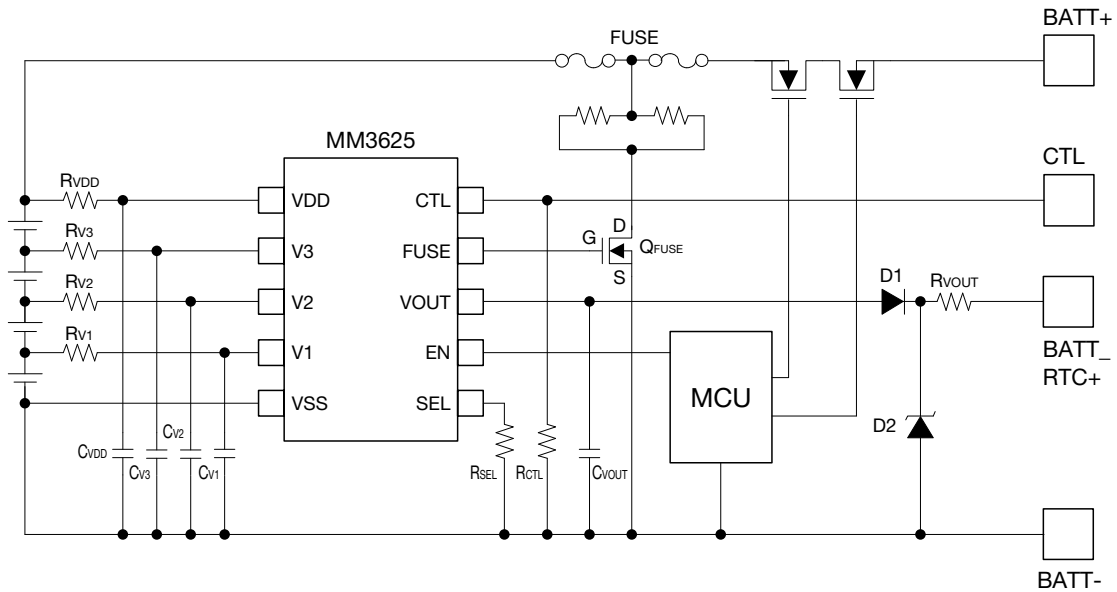

· 3 cells protection circuit

